

Mechanical Tree Planters

John P. Slusher
School of Forestry, Fisheries and Wildlife

Mechanical tree planters can speed seedling tree planting where several thousand trees are involved and where the terrain is not too steep nor too rough for mechanized equipment.

Hand planting is more satisfactory in small areas, on steep terrain, and on extremely rough rock- or debris-covered land. Hand planting also is necessary where the size of the seedlings prevents proper planting by machine.

Mechanical planting usually is not warranted for less than 1,000 seedlings because of the time involved in acquiring, transporting and using the equipment.

Mechanical planters

Many types of mechanical tree planters are available; they all consist primarily of a device pulled behind a tractor that creates a slit in the soil. A seedling tree is placed in the slit and the packing wheels on the planter close the slit and firm the soil around the seedling. In addition, some are equipped with furrowing attachments to scalp part of the planting area, while more recent designs have spray attachments for applying herbicides to control unwanted vegetation.

Tree-planting machines are of three general types: The **floating** type is attached to a tractor by a three-point hitch so the entire machine can be raised from the ground by the hydraulic lift on the tractor. The **semi-floating** type has its front end carried by the tractor and its back end carried on wheels; it cannot be lifted by the tractor. The **trailer** type has all or nearly all its weight carried on its own wheels.

Several models can be broken down into two or three basic parts in about five minutes. Each of these parts is light enough to be handled by one or two men and all parts can be transported in a pick-up truck.

Planting speed varies with the ground conditions, the species and size of seedlings, and the experience and skill of the crew. Rates of 400 to 1,000 trees per hour are reported.

Most planting machines consist of a rolling coultter, a trencher, an operator's seat and packing wheels (Figure 1). These parts are attached to a sturdy frame, usually equipped with a three-point hitch for use on a tractor with a hydraulic lift unit.

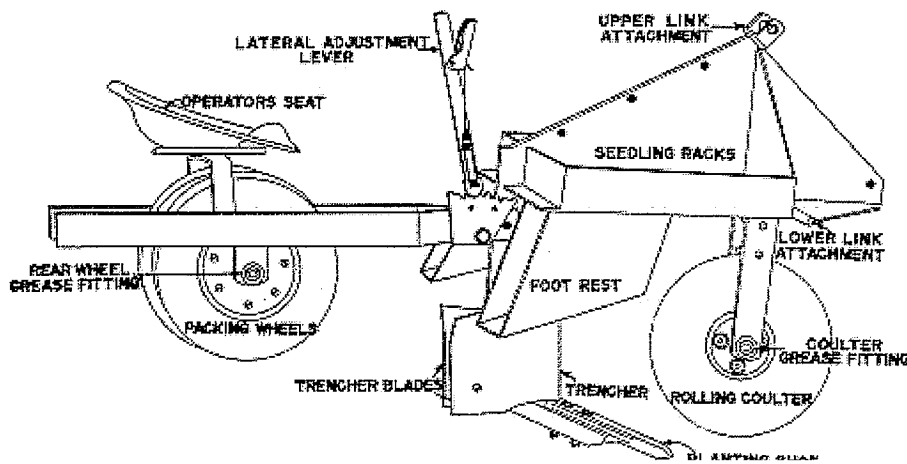

Figure 1

Mechanical tree planter

The **rolling coulter** is a disc-like cutting wheel that cuts through the ground surface and severs old roots, trash and other debris. It also serves to automatically raise the trencher over buried rocks, logs, etc. It should cut at a depth slightly below the trencher point.

The **trencher** on many planters is essentially a moldboard plow with the moldboard cut away and replaced by metal sides moving parallel with the landside. The trencher's purpose is to make an opening in the soil sufficiently wide and deep to receive the roots of the seedling tree in a way that they are not twisted, L-shaped, or crowded into a single plane.

The front of the trencher is shaped so that it lifts the soil from the trench upward and to the side, where it remains until the trencher has passed. Then it is deposited back into the trench from above, falling downward among the roots of the tree being planted, carrying the roots downward while maintaining good distribution of the branch rootlets.

Packing wheels usually are two wheels following the trencher that are set on an angle to force the furrow to close around the seedling and to pack the soil around the tree. The weight of the operator normally provides the weight necessary for proper soil compaction.

Planting success

Success in establishing a forest plantation is critical at four stages:

- Preparation of the site
- Selection and care of the planting stock
- Making the planting
- Care of the seedlings after planting

Failure to successfully complete any of these steps can cause seedlings to die or have limited growth.

In general, some form of site preparation will be needed for planting in the northern half of Missouri. Site preparation is seldom needed on the typical abandoned field in the Ozark areas, unless regrowth of woody species is well advanced. However, it is usually needed in bottomlands and on good soils where there is a heavy continuous sod or dense weed and shrub growth. On cut-over timber or sprout-infested areas, site preparation is necessary and planting should not be considered until over-topping vegetation is controlled.

Control of competing trees, brush, grass and weeds makes planting easier and creates more favorable conditions for newly planted seedlings. Because of many problems associated with scalping and furrowing to control weeds, unwanted vegetation is often controlled with chemicals.

An erosion hazard is often created when trees are planted in rolling or hilly ground. Planting rows are likely to become waterways when slopes are greater than 5 percent. In these situations, contour planting may be necessary.

The direction of planting rows should be determined in advance. Chemicals may sometimes be used the fall before planting to eliminate grass competition in planting rows without disturbing the ground protection.

Planting stock

One key factor in a successful plantation is giving proper care to good quality planting stock. Stock quality should be judged mainly on the basis of size and balance. Both very large and very small trees are difficult to properly plant mechanically. Seedling stem diameter should be between 1/8 and 3/8 inches.

If the roots of the seedlings have not been pruned, this should be done before planting. In general, pruning the seedling roots to a standard length of 8 inches from the root collar (Figure 2) will make planting easier and increase survival rates. Slightly longer root lengths should be kept on hardwood seedlings with taproots, such as walnut and various oak. Pruning should be done with a sharp ax to avoid "peeling" small roots.

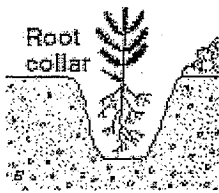

Figure 2

Best success is obtained when the seedlings are planted as soon as possible after arriving from the nursery. If planting will be delayed, the packing material around the roots should be kept moist and the seedlings should be stored in a cool, shady location or in cold storage at 33 to 40 degrees. If planting is to be delayed more than a week, the trees should be "heeled in."

Roots of planting stock must be protected from drying or freezing. Stock packed tightly in rolls or bales for more than a week without moistening may be seriously injured from heating or drying.

Regardless of the method of planting used, keep in mind the following points:

- Seedling roots must not be allowed to dry before or during plantings. All trees except the ones needed for a supply on the planter should be kept wrapped in a cool, moist condition in the shade of other trees or beneath a vehicle. If the roots of trees in a bundle are tangled together, each tree should be separated gently so that the small roots are not stripped. Trees on the planter should be covered with wet cloth or kept in water or a mud slurry in seedling racks (Figure 1).
- The roots of the seedling when planted must be in a natural, uncurled, untwisted position. Make certain the furrow or hole is deep and large enough. Root pruning is better than planting **L- or J-shaped** roots.
- The seedling should be planted in an upright position at the same depth or only slightly deeper than it was growing in the nursery (after the soil has settled, the root collar should be covered).
- The soil around the seedling after planting must be firm to prevent the roots from drying out. Seedlings should resist gentle lifting pressure.

Don't attempt to plant in frozen or snow-covered ground or on clay soils when the soil is too wet to pack properly. It is more desirable to keep stock in cold storage for as long as a month until moisture conditions improve than to plant in wet, muddy, heavy clay soils or in extremely dry soils.

Planter operation

A work crew of three usually is used in machine planting: a tractor operator, a tree planter and a tree packer who follows the machine to check the planting work and correct poorly planted seedlings.

Before beginning to plant, check:

- Planting shoe (Figure 1), for:
 1. Proper angle
 2. Proper alignment with coulter and trencher
 3. Excessive wear
 4. Loose bolts
- Packing wheels for:
 1. Bearings greased
 2. Freedom of movement (not mud packed)
 3. Proper inflation of tires
- Rolling coulter for:
 1. Bearings greased
 2. Excessive wear
 3. Proper vertical alignment
 4. Freedom of movement

Trees are taken from the seedling racks on the tree planter and held with the roots away. Single trees are then transferred to the planting hand and usually held between the forefinger and thumb at about root-collar depth in preparation for planting. Planting is done by placing the tree in the ground between the trencher blades (Figure 1) well forward of the soil that falls in the trench. The tree is held upright or leaned a little backward with the knuckles touching the ground. The operator follows through, holding the tree in position until the forward motion of the machine and soil falling back in the slit holds the tree in place.

Tractor speed affects quality of planting. It is important to have a tractor with enough power to pull steadily at slow speeds. Some factors that determine planting rates are soil quality and condition; presence of stumps, stones, etc.; size and condition of planting stock; and skills of the planter operator.

When the planting rate is too rapid, a number of trees will be planted shallow or flat. It is important that the speed of the planting machine be geared to the operator's ability to place the tree properly.

Proper spacing may be determined in a number of ways. Various marking devices attached to the tractor or planter may be used to determine distance between rows (if the ground is soft, the tractor wheel prints can be used).

Spacing in the row may be marked by cross lines laid out with a cultivator shovel, or by the use of bell devices on the planter or tractor wheels. Many persons are able to develop a tree-planting rhythm that gives fairly accurate spacing.

Each tree row should be walked to check for:

- Proper planting depth and root position
- Tree in a vertical position with the soil properly packed around the roots
- The planting furrow not filled with trash and debris.

Table 1 lists some common problems encountered and gives suggested corrections for when you are using a mechanical tree planter.

Table 1
Common planting problems and suggested corrections

Problems	Corrections
Packing wheels do not track, perhaps even run over trees.	<ul style="list-style-type: none"> • Use lateral adjustment lever (Figure 1) to align planter. • Ground hilly or rocky: Adjust the lower linkage (Figure 1) of three-point hitch so machine rides level. • Add stabilizer bar to lower linkage attachments. • Plant on contour.
Trees planted shallow or flat.	<ul style="list-style-type: none"> • Coulters too small for stock. Root prune if root length excessive. • Ground hard. More weight needed on coulters-trencher unit. • Increase the ground entering angle of the trencher by shortening the upper linkage (Figure 1). • Decrease the tractor speed to match planting speed. • Check for worn coulters or planting shoe. • Rocky ground or shallow rock causing coulters and trencher to ride high. • Planter operator removing hand too quickly after placing tree between the trencher blades or not placing tree into furrow quickly enough. • Check hydraulic lift setting.
Trees planted too deep.	<ul style="list-style-type: none"> • Operator turning loose of seedlings before soil catches and holds roots. • Adjust planter depth by lengthening the upper linkage. • Check hydraulic lift setting.
Planting slit not closing (most often found in heavy sods and soils).	<ul style="list-style-type: none"> • Lengthen the upper linkage so trencher will run on horizontal. • If angle of packing wheels can be adjusted, consider

	<ul style="list-style-type: none"> making these more vertical. • Check the adjustment of the coulter to be sure it is running true-vertical and with the direction of the tractor. • Soil conditions too wet for soil type. Allow to dry. Disc. • Walk with row and individually pack with feet.
Trash and old grass packs between coulter and leading edge of trencher.	<ul style="list-style-type: none"> • Too much debris. Burn off old weeds and fine grass. (State laws on burning should be observed.) • Plowing and discing the summer before planting should be done if problem is suspected and if erosion is not a hazard. • Check coulter depth. If not cutting trash, set deeper. • Remove coulter.
Dirt piles up between the trencher and packing wheels (most common on plowed and disced ground).	<ul style="list-style-type: none"> • Lengthen the upper linkage so trencher will be horizontal -- not tilted.

Changes in soil types or topography may call for minor adjustments during the planting operation.

Persons planting trees form their habits early. Once formed, they are difficult if not impossible to break. Check a new planting crew often to correct faulty planting methods before they become a habit. High-quality planting requires advanced planning, well-maintained equipment and conscientious, reasonably skilled workers.

Certain rules of safety should be observed:

- A first aid kit should be available to the planting crew
- The tractor operator should avoid sharp turns that might tip the planting machine with the tractor wheels
- The tractor should be equipped with a rear-view mirror
- The planter operator should wear close-fitting clothing, hard hat and goggles or other adequate eye protection. The operator should be alert for sticks, logs or brush that may poke up through openings in the machine.
- Care must be maintained in planting to avoid injury to hands by the packing wheels.

Information on tree planting can be obtained from your local MU Extension center, Department of Conservation farm forester or Soil Conservation District office.

Planting stock may be obtained through the State Forest Nursery at Licking or from a number of private nurseries.

Financial assistance with planting programs and improvement of existing woodlands is available through the local office of the Agricultural Stabilization and Conservation Service.

Web maintenance 11/22/05

Reviewed October 1993

Order printed copies

G5009, Mechanical Tree Planters

- **Price**
\$0.50
- **Availability**
618 copies

Exchanges

Use our [feedback form](#) for questions or comments about G5009.

On this page

- [Mechanical planters](#)
- [Planting success](#)
- [Planting stock](#)
- [Planter operation](#)

Related page

- [G5008 How to Plant Forest Trees](#)

Satisfaction survey

Please answer [three short questions](#) about this Web page.

- [© 1993 to 2007 Curators of the University of Missouri, all rights reserved, DMCA and other copyright information](#)
- [Published by University of Missouri Extension, guidelines to reprint or copy](#)
- [Disability resources and statement of nondiscrimination](#)
- [Send](#) comments or questions to the Web team

University of Missouri Extension

© 1993 to 2007 Curators of the University of Missouri, all rights reserved